



## Cycling

This guidance note outlines the Council's policies on cycling and amplifies upon guidance contained within existing transportation strategies and development plans. The note will form a material consideration in the determination of all relevant planning applications.

To encourage a greater number of journeys to be made by bicycle, this note sets out how developers will be expected to provide facilities for cyclists in the preparation of relevant development schemes. It also provides design guidance on the construction of cycle routes and cycle parking facilities.

# 15

*Available in alternative formats*

### Cycle routes

**Safe, coherent** and **attractive** cycle routes, either on or off road are essential to encourage cycle use. A number of cycle routes have recently been constructed and many more are proposed. To maintain the integrity of these, any proposal which would sever an existing or proposed cycle route will be resisted unless the proposal makes adequate compensatory provision.

Developers should link developments which would generate or attract a significant number of trips with the network of cycle routes and in turn to populated areas and/or everyday facilities. In some cases, the enhancement or improvement of the existing

network may also be required. Safe routes within the confines of a development site must also be provided, to ensure that cyclists can access cycle parking areas conveniently and safely.

Where a development site is separated from housing, schools or shops by busy roads, safe crossings will need to be provided. Toucan or Pelican crossings will usually be the most appropriate, where criteria relating to traffic flow levels are met. A combination of cycle lanes and staggered crossings, advance stop lines and directional signage will be required to enable cyclists to negotiate or bypass hazards such as major roundabouts and junctions in safety.



The segregation of cyclists from dangerous, fast flowing vehicular traffic on arterial routes is often necessary. However, away from arterial routes, where the prime purpose of road space is one of local circulation, it is desirable for road space to be allocated to cyclists. New residential roads in particular should be designed with the needs of cyclists and with low traffic speeds in mind. Traffic calming may be required to achieve this. Cycle lanes are not usually required where cyclists would use minor roads carrying fewer than 4000 vehicles per day, travelling at speeds of 20 mph or less.

Routes used primarily for commuting between populated areas should be well lit to enable commuting at night and during the winter months. Lighting columns and signage should be located so that they would not obstruct cyclists or disabled users of the path or highway. Tactile and/or coloured markings should be used to segregate areas used by cyclists from areas used by pedestrians. Where off-site works are required, the Council will impose a condition requiring the works to be implemented before the new use or development may commence and to be retained thereafter.



### Disused railway lines

The re-use and restoration of disused railway lines to create cycling routes will be supported. Where cyclists would share these routes with pedestrians, they should measure a minimum of 3.0m in width.



Where it is anticipated that horseriders will use part of a converted route, a segregated bridleway measuring a minimum of 2.0 m in width will be required. Such bridleways should be surfaced in grassed gravel. This surfacing is made up of a 150mm deep aggregate base course, covered in a 150mm deep mixture of aggregate and top soil and seeded in ryegrass.

Converted railway lines should retain their openness and green appearance and development on the edge of, or adjacent to the trackbed will not be permitted if it would prove overbearing. Measures to prevent access by motorcycles or scrambling bikes may need to be incorporated into the scheme.

In some cases, the strengthening of existing bridges and the replacement of dismantled bridges over busy roads will be required where this would help link a development with populated areas and/or everyday community facilities. Where appropriate, developers will be required to enter into an Obligation under Section 106 of the Town and County Planning Act 1990 to secure the payment of commuted sums for the maintenance of any such bridges.

### Canal towpaths

Improved canal towpaths can also provide safe, coherent routes for cyclists. Where cyclists are permitted by British Waterways to share a towpath with other users, it is desirable for the path to measure 3.5m in overall width. A geotextile fabric should be used in the construction or reinstatement of a path and its finished level should be higher than the adjacent ground, in order to allow water to drain. All proposals for the adaptation and improvement of towpaths should take into consideration on-going maintenance costs.

### Amenity considerations

Landscape and amenity issues are important considerations in assessing the suitability of cycle routes. New routes should avoid areas of land beneath the crown spread of important amenity trees as compaction and excavation works can cause serious damage to roots. Meandering cycle routes are also aesthetically preferable to straight or angular routes.

Any work occurring close to important trees should comply with BS 5837 1991 - "Guide to Trees in Relation to Construction", to ensure that damage does not occur. Cycle paths should not breach existing mature hedgerows and should also avoid the rooting zone of hedges. A detailed survey of all nearby trees and hedges should be submitted with proposals for the construction or improvement of a cycle path.

All proposals for the construction of cycle paths must be of a high standard of design. Incongruous engineering measures, such as steel bollards, fencing or steel palisade fencing will not be permitted where they would have an unacceptable effect on their locality's landscape and character. Resin bonded aggregate is preferable to the use of rolled black or red asphalt on off-road cycle routes in rural areas. Routes which detract from the quality of the townscape and landscape or the character and setting of Listed Buildings and Conservation Areas will not be permitted.

“Sheffield” Stand

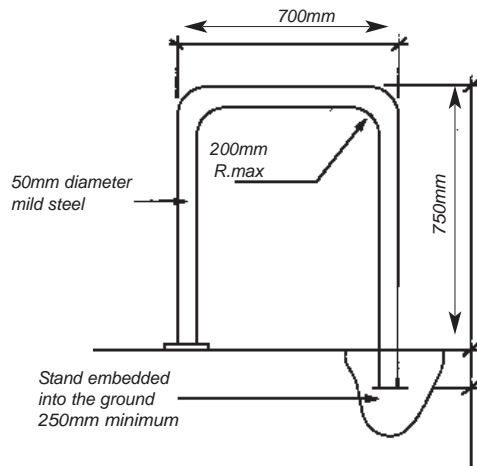

Row of “Sheffield” Stands

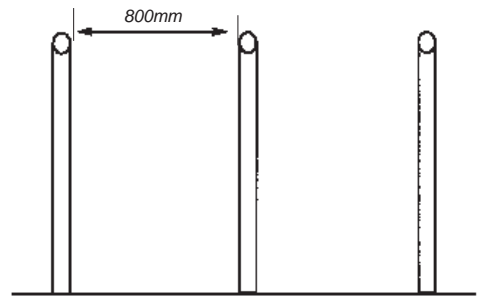

Cycle parking

New developments must make provision for the safe parking of cycles. A series of **minimum standards** have been adopted for different types of development. These are shown in Box 1.

Any development resulting in the loss of an existing cycle parking facility will be resisted, unless the proposal makes adequate compensatory provision.

In Wrexham Town Centre and in the district shopping centres of Cefn Mawr, Chirk, Coedpoeth, Gresford, Gwersyllt, Ruabon and Rhos, developers may contribute towards the provision of off-site, communal cycle parking facilities in lieu of a facility to serve the individual use.

Where major developments are proposed (a large industrial unit, office complex or housing scheme for example) car parking standards may be reduced where the development would incorporate measures to further reduce reliance upon travel by car. Such measures should be detailed within a **Green Transport Plan**, produced by the applicant. Green Transport Plans propose measures which promote environmentally friendly forms of travel in preference to the car. To encourage

cycling, measures could include financial incentives for cyclists and the provision of facilities such as showering and changing areas.

Where appropriate, the developer will be required to enter into an Obligation under Section 106 of the Town and Country Planning Act 1990 to ensure that the agreed measures are implemented and thereafter retained.

The design of cycle parking facilities

Sheffield stands (n-shaped steel bars set into the ground) are best suited for short stay parking. These should be:

- 750 mm high, 700 mm long and set at least 250 mm into the ground;
- spaced a minimum of 800 mm apart;
- polyester powder coated, coloured to match existing street furniture or buildings, (or else painted in black); and
- be protected from the elements by a wall, shelter or canopy.

Hitching rings or hoops affixed to walls and buildings, can also be used where space is limited and where Sheffield stands cannot be accommodated.

These should be positioned at 1.8m intervals and 750 mm above ground level.

In areas where long stay bicycle parking facilities are required (in excess of 8 hours in length) developers should provide more secure parking facilities in the form of cycle cages or lockable bicycle shelters. Alternatively, secure compounds within buildings may be acceptable, providing that they are located at ground floor level and are accessible.

Planning applications for the development or redevelopment of public transport facilities must make provision for cyclists through the provisions of safe and secure cycle parking facilities and cycleways. Secure cycle shelters and lockable cages will be preferable to Sheffield stands or wall hoops in such locations.

Single panel advertising or sponsorship panels incorporating logos or guidance and which are attached to groups of cycle stands may be acceptable where these would not result in visual clutter. Where advertisements are deemed acceptable, the advertisement panel should not exceed 600 cm<sup>2</sup> in area.

## Minimum cycle parking standards

{Typical dimensions of a bicycle : 1.8 m(L) x 0.6 m(W)}

Type of use	Number of cycle spaces required
<b>Shops</b>	
Small convenience shops	1 per 100m <sup>2</sup> gfa (or part thereof)
Food supermarkets	1 per 150m <sup>2</sup> gfa (or part thereof)
Non-food retail	1 per 200m <sup>2</sup> gfa (or part thereof)
Banks, building societies, betting shops and other offices found within shopping areas	1 per 60m <sup>2</sup> gfa (or part thereof)
Food and drink outlets	1 per 60m <sup>2</sup> gfa (or part thereof)
<b>Industrial uses</b>	
Administrative offices, research & development uses	1 per 350 m <sup>2</sup> gfa (or part thereof)
General industrial uses	1 per 500 m <sup>2</sup> gfa (or part thereof)
Storage and distribution uses	1 per 1000 m <sup>2</sup> gfa (or part thereof)
<b>Residential uses</b>	
Hotels and guest houses	1 per 10 guest beds
Residential care homes, nursing homes and hospitals	1 per 10 employees
Residential schools, residential colleges and residential training centres	1 per 10 staff & 1 per 5 students
Dwellings	No prescribed standard. However, secure and convenient communal cycle parking areas may be required in appropriate circumstances (e.g. higher density developments with limited, or no car parking).
<b>Community uses</b>	
Primary and secondary schools	4 per classroom
Sixth form & FE Colleges	1 per 35m <sup>2</sup> gfa
Medical and health centres	2 per consulting room
<b>Leisure uses</b>	
Art galleries, museums and libraries	1 per 150m <sup>2</sup> gfa
Cinemas, leisure centres, bingo halls, concert halls	1 per 75 m <sup>2</sup> gfa
<b>NB:</b> gfa = gross floor area A minimum 1 space should be provided in all cases	

## The location of cycle parking facilities

All cycle parking areas should be located:

- in a convenient and prominent position, usually adjacent to the entrance to the building or use which they serve and be lit or positioned close to sources of light;
- so that they can be monitored by closed circuit television or be visible to on-site security staff and be sited; and
- away from trees, to minimise damage to root structures and to prevent damage to bicycles from sap and bird droppings.

Small clusters of cycle parking facilities are preferable to large, central parking compounds. All stands should be located so as not to obstruct or endanger pedestrians, particularly blind or partially sighted pedestrians and wheelchair users. Bollards painted with contrasting stripes may be required to give additional protection in this respect. Cycle parking areas may also need to be surrounded by tactile markings.

Cycle parking facilities should not damage the area's townscape or landscape. In Conservation Areas and close to Listed Buildings, special attention should be paid to the siting, design and materials used for the parking facility. Measures which detract from the character or setting of a Listed Building or which damage the character of Conservation Areas will be resisted.



For further information contact:

**Chief Planning Officer, Lambpit Street, Wrexham, LL11 1AR.**

**Tel: (01978) 292019 Fax: (01978) 292502**

[www.wrexham.gov.uk](http://www.wrexham.gov.uk)

Adopted April 2000